

WIND PACT PLUS

“NOT JUST ANOTHER WINDOW”™



COASTAL SERIES

Why **WIND PACT PLUS** Windows for Your Home?

Not All Vinyl Is Created Equal
CWS's vinyl compound is made using state-of-the-art computerized blending and compounding equipment. The resulting vinyl extrusions perform equally well in South Florida's humidity and severe weather.

CWS Vinyl Is More Opaque To Protect Against Harmful Ultraviolet Light



CWS vinyl is more opaque and allows less harmful ultraviolet light penetration.



Other vinyl allows too much harmful ultraviolet light to penetrate.

Watch Out for Impostors

CWS uses color-stabilized vinyl to prevent discoloration and keep your windows looking new. Vinyl windows of lesser quality may start out white but can end up looking dingy and discolored after normal exposure to the elements.



Competitive vinyl salvaged from lesser quality windows that were replaced. Photo not altered.

ADDS storm protection designed to meet Dade County.
PROVIDES a greater level of safety and security.



ADDS beauty and value to your home.

ADDS more comfort and energy savings.

Summer: Cardinal Low-E Glass Keeps the Cool In and the Heat Out.

With Cardinal LoE² Glass your windows become "The Invisible Energy Appliance".

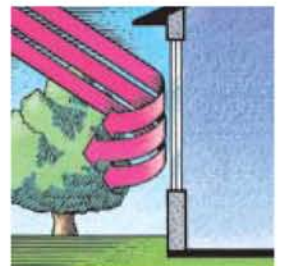

Experience and Technology: That's How We Build Our Windows



Picture Perfect Glass

We carefully inspect every piece of glass and insulated unit to guarantee its quality before installation into our windows.

Our Laminated Glass

Cardinal Sea-Storm Laminated Glass is designed to meet stringent Dade County Protocol for windows used in high wind coastal areas.

High-Performance Glass

Cut with technically advanced, high-speed machines, the glass is then assembled into our high-performance insulated units.



Experienced Craftsmanship

Dedicated craftsmen with years of experience oversee all aspects of our window production.

Precise Profile Cuts

Precise cuts of our vinyl profiles allow for tight-fitting corners that when welded provide a strong, watertight seal.



A Unique Vinyl Frame that Offers Beauty, Style and Durability

SINGLE HUNG

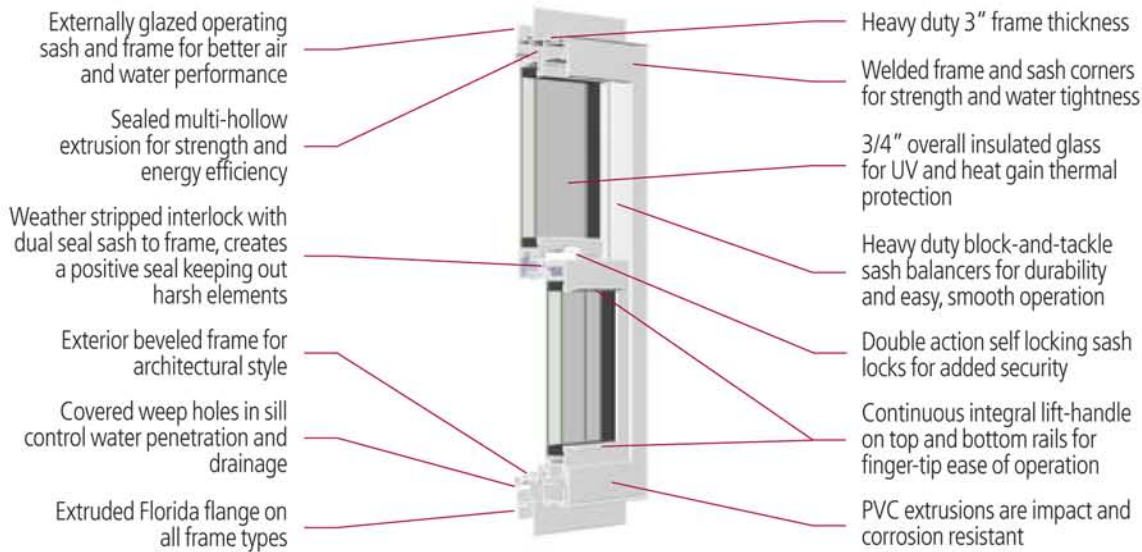

HORIZONTAL SLIDER

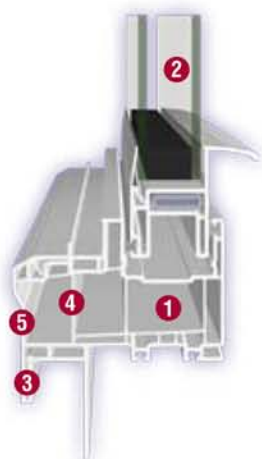
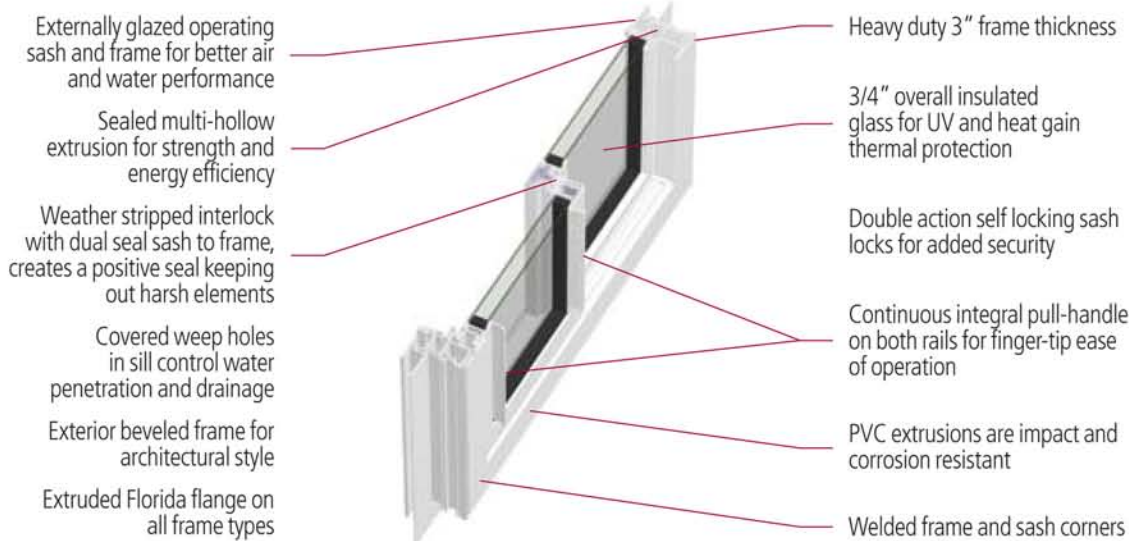

Advanced Design and Engineering

- 1) Multiple hollow chambers for strength and insulation.
- 2) Dual-pane insulated glass with double-strength glass (standard).
- 3) Extruded Florida flange on all frame types.
- 4) Thick vinyl walls for added structural integrity.
- 5) Covered weep holes in sill control water penetration and drainage.

Advantages of Cardinal LoE²

For the advantages of laminated glass with a reduced solar heat gain, Cardinal offers LoE² Coatings. Though virtually invisible to the eye, Cardinal's patented LoE² coating reduces solar gains, thus reducing air conditioning costs.

Neutral in color, the microscopically thin LoE² coating in laminating glass has high visible light transmission and low outdoor and indoor reflectivity.

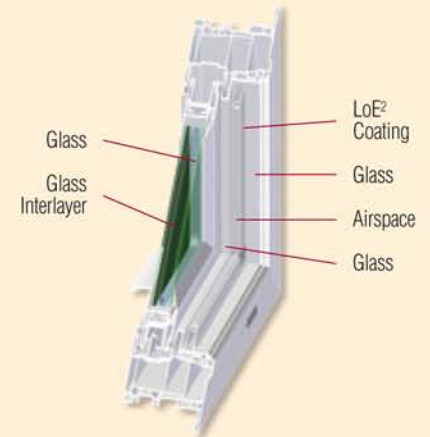

How Laminated Glass Protects the Building

If the building envelope is breached through a broken window, wind may enter the building causing an increase in pressure that could lift the roof and push the walls outward.

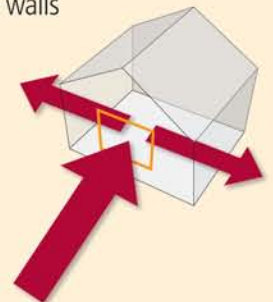

Laminated glass helps to preserve the building envelope, keeping wind and other elements outside.

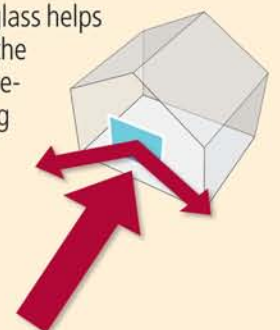

Our People Make the Difference



Your Windows are built by a team of skilled people who take pride in every step of the manufacturing process to insure your satisfaction.

We've been doing this for over 20 years.

**So You Can Feel Safe
and Secure When You . . .**

Choose Product Styles That are Right for You

Choose from many styles and shapes including By-Pass, Pocket and Ninety Degree Patio Doors! All windows and doors available Non-Impact or Impact.

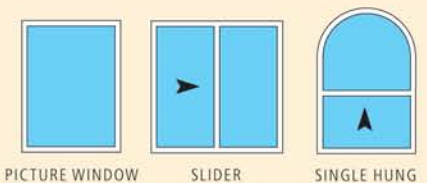

PICTURE WINDOW

SLIDER

SINGLE HUNG



CASEMENT



AWNING

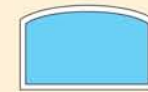

ARCH TOP



OCTAGON

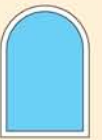

ROUND TOP

Sliding Patio Door

Our vinyl sliding patio door features:

- Adjustable tandem rollers for easy operation
- Large, easy-to-operate locking handle
- Custom sizes available upon request
- Multiple configurations with all panels sliding



Thermal Performance Data

Window Style	Glass Type	UV Block	Visible Light Transmittance	Total Unit U-Factor	Solar Heat Gain Coeff.
Single Hung	Clear/Clear	.44	82%	.47	59
	LoE ² /Clear	.86	70%	.33	29
Horizontal Slider	Clear/Clear	.44	82%	.47	58
	LoE ² /Clear	.86	70%	.33	29
Picture Window	Clear/Clear	.44	82%	.47	61
	LoE ² /Clear	.86	70%	.32	33
Casement	Clear/Clear	.44	82%	.45	48
	LoE ² /Clear	.86	82%	.32	25
Patio Door	Clear/Clear	.44	82%	.47	62
	LoE ² /Clear	.86	70%	.33	34

¹ Ultraviolet (UV) light block calculations performed using Lawrence Berkeley Laboratories Window 4.1 program. Percentages indicate amount of UV transmittance blocked from the interior using a 3/4" glazing unit.

² Visible light transmittance indicates the amount of outside light reaching the interior as calculated using center of glass. Higher percentages mean more outside light reaches interior.

³ U-factor represents the amount of heat transfer as measured in accordance with NFRC 100-2001, calculation uses total window unit, and assumes 3/4" glazing with a 1/2" airspace. Lower is better.

⁴ Solar heat gain coefficient (SHGC) measures the amount of solar radiation entering the building. As measured per NFRC 200-2001 with the Window 4.1 and Frame 4.1 modeling programs. Lower is better.

Certified To Meet or Exceed Expectations

All CWS windows are AAMA and NFRC certified, and ENERGY STAR® qualified.



Wind-Pact Plus Large Missile Impact Windows

- Provides a greater level of safety and security
- Reduces danger of flying or falling glass
- Resists forced entry
- Dampen unwanted outside sounds
- 67.5 DP-SH, 60 DP-HS, 67.5 DP-Casement, 60 DP-Patio Doors, 67.5-Awning
- Tested to Miami-Dade County, Florida and ASTM specifications for impact
- Available with energy efficient LoE2 Glass

White or Adobe

CWS vinyl windows are available in two easy-to-clean colors: white or adobe. Both colors are integrated throughout the vinyl for durable color.



1900 SW 44th Avenue
 Ocala, Florida 34474
 Web Site: WWW.CWS.CC

Your Authorized Custom Window Systems Dealer: